



Microgrid ESS Solution V1.0

500kW@1MWh
20 Feet Container

December 2024

CONTENT

1. Project Overview	1
1.1 Project overview.....	1
1.2 Analysis of the project	1
1.3 Overall design	2
2. PV Configuration	5
3. Design of Energy Storage System	6
3.1 Battery capacity.....	6
3.2 Battery configuration	6
3.3 Structure of the energy storage system	7
3.4 Container System.....	7
3.5 Introduction to the MPS series hybrid inverter	13
3.6 Introduction to energy management systems (EMS)	18
4. Supply List.....	24

1. Project Overview

1.1 Project overview

The project, located in Europe, does not yet have any specific application. Therefore, this project plans to construct an on-grid/off-grid power supply system according to requirements of clients, which mainly consists of a photovoltaic (PV) system, a 500kW/1MWh LFP energy storage system, and a generator set. The hybrid energy storage system adopts integrated design, the battery and the MPS series hybrid inverter, which contains PCS modules and MPPT modules (PV controller), are configured in a 20 feet container together with auxiliary components.

1.2 Analysis of the project

- (1) Project name: 500kW/1MWh hybrid microgrid system
- (2) Project location: Europe, without specific location (no derating <3000m, derating 1% every 100m above 3000m)
- (3) Project scope and capacity: a 600kWp PV system, 1 set of 500kW/1MWh LFP energy storage system, and a generator set (with a minimum capacity of 250kW in total).

Each 500kW/1MWh energy storage system configures 1 set of MPS series 500kW hybrid inverter (MPS0500), which reduces the installation costs through an integrated solution that supports PV, battery, load, grid or generator access at the same time. The MPS0500 outputs 400Vac/50Hz 3-phase AC electricity to supplies energy to loads in on-grid mode, off-grid mode, or on-grid/off-grid auto switching mode.

(Note: In the case that both a grid and a generator set connects to the Grid port of the MPS, the ATS configured by clients should be Auto Transfer and Auto Restore type and meet the requirement that the switching time between two energy sources is ≥ 5 seconds.)

(4) Operation logic: Self-use, supplies residential loads using solar power primarily.

(5) Grid port voltage/frequency: three-phase 400Vac/50Hz.

(6) Layout type: "container" type arrangement of energy storage system. Each 500kW/1MWh energy storage system integrated with an 1MWh battery system, 1 set of MPS0500, fire protection system, air conditioning system, illumination, etc.

(7) EMS: The EMS system is configured with a 10.1-inch screen for remote monitoring of the operating parameters, alarm information and fault information of the energy storage system, etc.

1.3 Overall design

The project is a hybrid microgrid system that includes a generator set, could work in on-grid or off-grid mode. The total installed capacity of the PV system is approximately 600kW_p, which will be respectively imported into the PV combiner boxes. After combining, the outputs from the combiner boxes are connected to the MPPT modules of the 1 set of MPS0500. The MPPT modules connect with the battery system on the DC bus after the voltage has been bucked or boosted. After being inverted, isolated and filtered, the AC power will be generated to supply energy to the

loads.

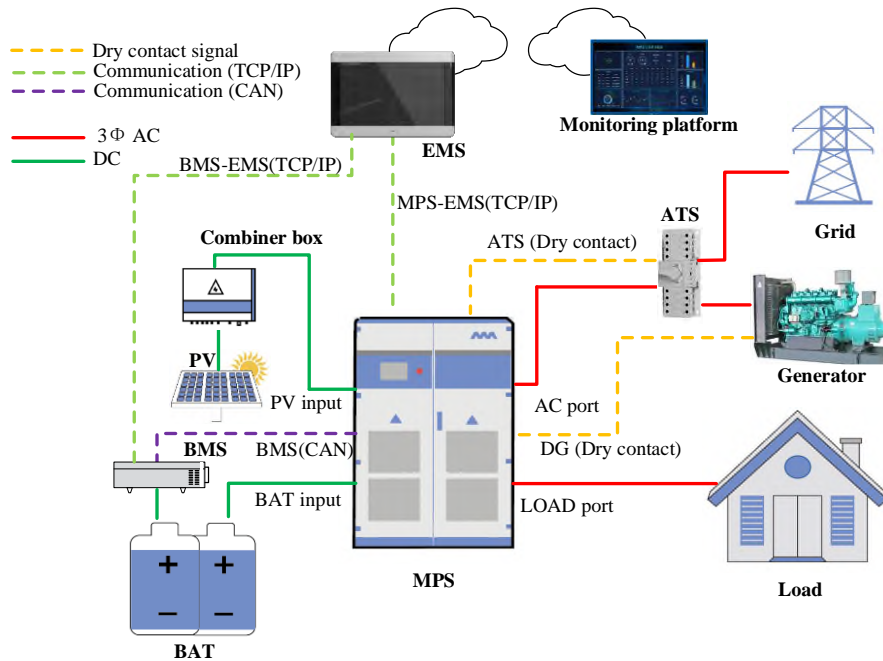

The energy storage system is comprised of 1 set of 500kW/1MWh system. Each 500kW/1MWh system is placed in a 20 feet outdoor container, including 1MWh battery system, 1 set of MPS0500, fire protection system and air conditioning system, etc., as shown in the image below:

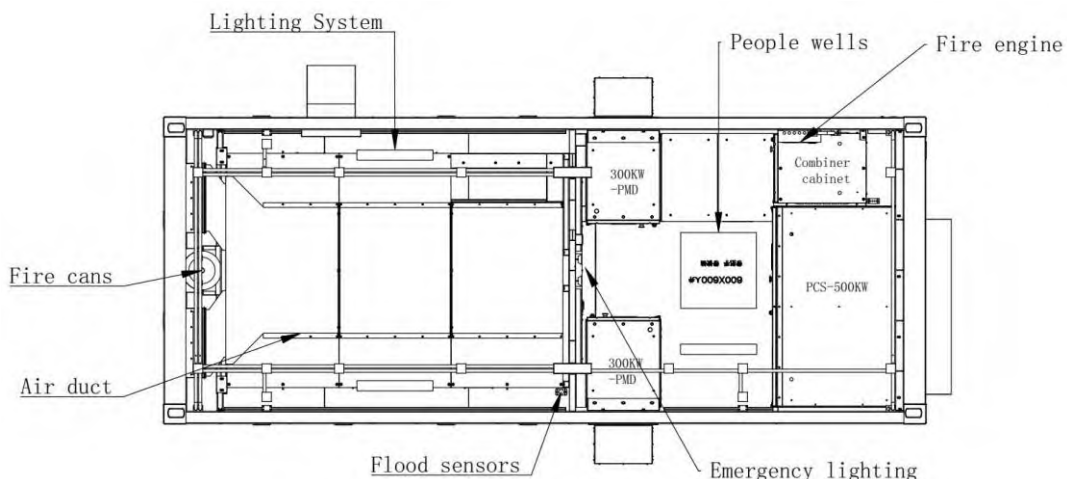

Configuration within the 20 feet container system

Each MPS0500 which configured 10 MPPT modules could connect a PV system with a

capacity up to 600kW. The total load power of a single MPS0500 running off-grid cannot exceed 500kW. If there are inductive, capacitive and other impact loads, the transient apparent power should be less than 550kVA, and the load steady-state and transient total output current should not exceed 722A.

Due to the big surge generated when motors and other inductive loads start, the declaration of inductive loads are as follows:

- (1) In the absence of the VFD/VSD, the motor power cannot exceed one-eighth of the rated power of MPS.
- (2) When configured with VFD, the motor power cannot exceed half of the rated power of MPS. (The motor is the most severe inductive load. Other inductive loads can refer to the above.)

2. PV Configuration

In this system, each MPS0500 configures 10 sets of 50kW MPPT modules to construct a 600kWp PV system, with its specifics details undetermined. Considering the 672~850V voltage range of the batter, The MPPT module is configured in “boost mode” : In extreme low-temperature conditions, the sum of the open-circuit voltages of the PV strings is \leq the minimum operating voltage of battery -20V.

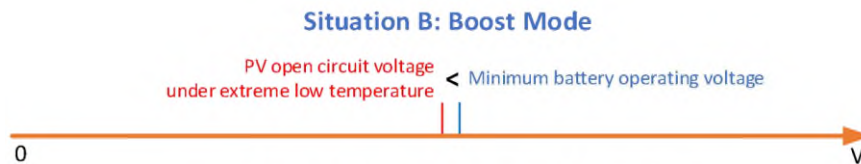

Diagram 2-Boost Mode Voltage Diagram

- (1) Under extreme high temperature, the maximum power operating voltage after the modules are connected in series is $>450V$ (Minimum PV full load operating voltage).
- (2) Under extreme low temperature, the open circuit voltage of the components connected in series is $< 652V$ (the lowest voltage of the battery-20V), which satisfies the Boost mode configuration principle of MPS.

Each series shall be separately imported into PV combiner boxes. (The combining circuit shall be configured by the client. Each combiner box corresponds to 1 MPPT module.) After combining, the outputs from those combiner boxes are connected to each MPPT module of each MPS hybrid inverter. In the case of smart combiner box used, the communication signals shall be connected to EMS with shielded twisted pair cable. And the signal lines and the power cables should be routed separately.

3. Design of Energy Storage System



3.1 Battery capacity

According to the product design and the capacity of the energy storage system, each MPS0500 is equipped with lithium iron phosphate battery modules: 75pcs 51.2V/280Ah (Nominal energy: 14.336kWh), with a total capacity of 1.075MWh.

3.2 Battery configuration

According to the product design requirements, the energy storage system uses 3.2V/280Ah and employs a three-tier system architecture. Every battery pack is configured as 16S1P with a nominal energy of 14.336kWh and is arranged in a drawer-type cabinet layout. Every 15 pack of 51.2V/280Ah LFP batteries connects in series to form a 215.04kWh battery cluster. Each MPS0500 configures 5 clusters of batteries with a total capacity of 1075.2kWh.

The specifications of each 1.075MWh battery system are listed below:

Number	Item	Figure	Rated voltage	Capacity	Notes
1	Cell		3.2V	280Ah	LFP
2	Pack		51.2V	14.336kWh	16 cells(1P16S)
3	Cluster		768V	215.04kWh	15 packs(1P240S)

4	Battery system		768V	1.075MWh	5 clusters
---	-------------------	---	------	----------	------------

3.3 Structure of the energy storage system

There is a total of 1 set of 500kW/1MWh ESS configured in this project.

3.4 Container System

3.4.1 Introduction to energy storage container

The containerized energy storage system adopts a standard ISO container design, which makes it convenient for transportation and installation and allows for easy combination of multiple container systems to increase storage capacity according to needs. The containerized system can be configured differently to meet the requirements of stable operation in various application scenarios.

In this project, the containerized energy storage system is applied in Europe, using 20 feet standard containers for assembly and transportation. This product features high specific energy, long lifespan, reliability, safety, and wide applicability, making it an intelligent and efficient energy storage solution for commercial or industrial applications.



External dimensions of the 20 feet container: 6,058×2,438×2,896mm (L*W*H).

3.4.2 Fire protection system

The fire protection system is designed according to the dimensions of the container. The configuration of the fire protection system is shown in the following image, which mainly contains temperature detectors, smoke detectors and a gas extinguishing controller.

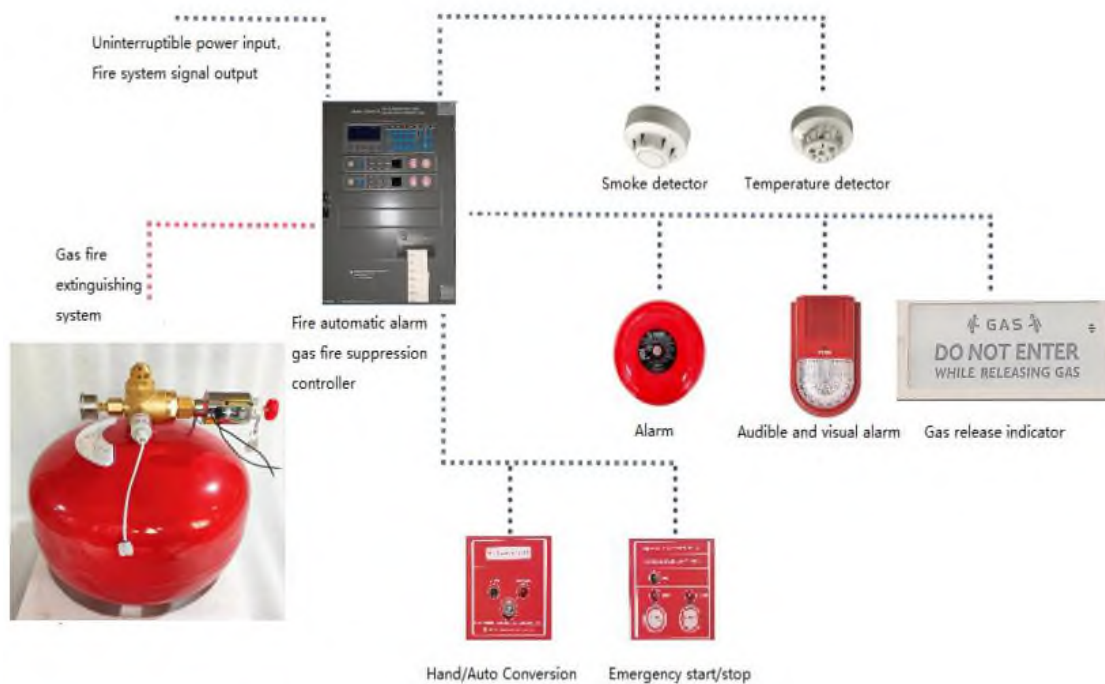

The fire protection system operates as illustrated below:

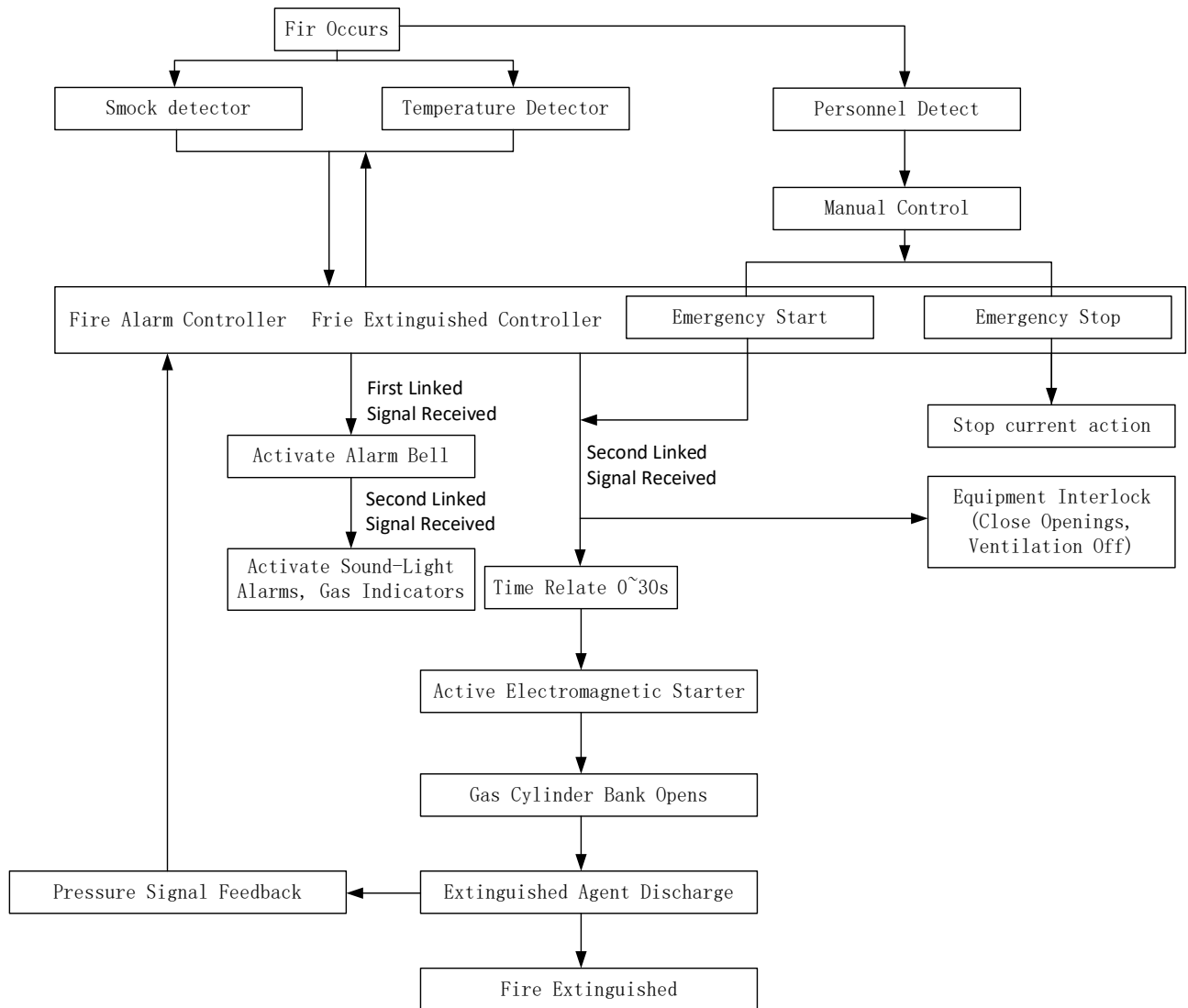

The fire protection system within the container uses FM200 (or NOVEC1230). The FM200 primarily acts through chemical suppression but also has physical suppression effects. It is colorless, odorless, clean, non-conductive, and does not contaminate protected objects, thus preventing damage to assets and precision equipment and ensuring safety for personnel. FM200 is an excellent clean gas extinguishing agent. Alternatively, the system can use NOVEC1230 suppression devices, which employ a

new solid-state gas generator. The fire suppressant used is liquid at room temperature and is a cooling-type environmentally friendly agent.

3.4.3 Industrial air conditioning

The air conditioning system is jointly controlled by the air conditioner, BMS, and ES-01. The air conditioner collects temperature and humidity data from the cabin, while the BMS gathers temperature data from the batteries. This data is then communicated to the EMS. Primarily based on the battery temperature and considering the environmental temperature and humidity, the EMS controls the air conditioner to heat, cool, or dehumidify, thereby maintaining suitable operating conditions for the batteries.

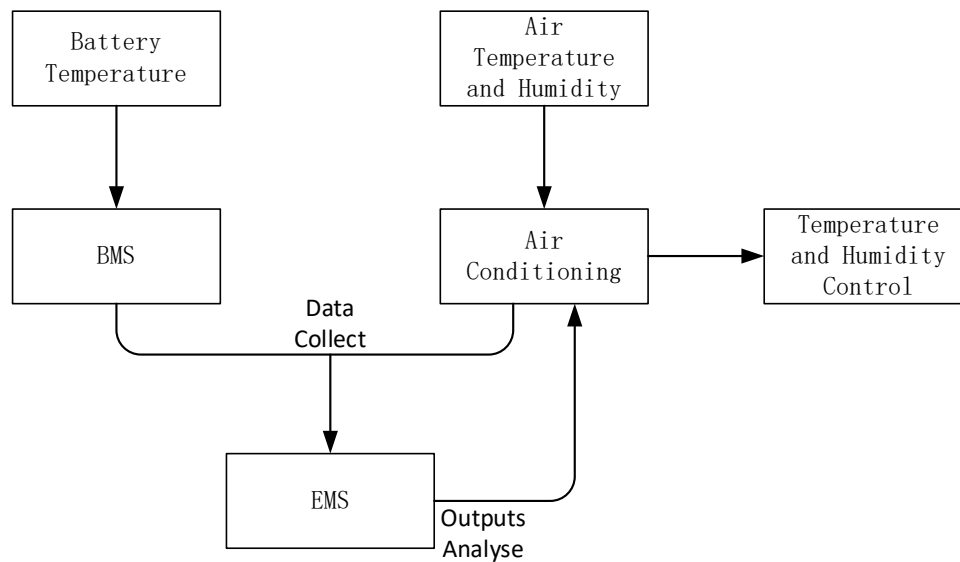

Features of the air conditioning include:

- (1) 9kW nominal cooling capacity (Each container equipped with 2 sets of 9kW air conditioning)

- (2) Suitable for container energy storage applications
- (3) Unique indoor side wiring box and outdoor side screw-less design, providing a neat and aesthetically pleasing appearance.
- (4) Integrated design, no need for a separate external protective cover.
- (5) Specialized dehumidification design, effectively reducing the relative humidity in the application environment.
- (6) Standard fan speed adjustment function.
- (7) Standard electric heating function.
- (8) RS485 interface, enabling remote monitoring via MODBUS protocol
- (9) Automatic restart upon power recovery, multiple alarm and protection functions.
- (10) High reliability, design for uninterrupted operation for 365 days/year for over 10 years.
- (11) Full front access maintenance, reducing service costs.

The key technical parameters of the air conditioning are shown as below:

Parameter	Specifications
Rated voltage	227Vac
Rated frequency	50/60Hz
Rated cooling capacity (W)	9300 (L35/L35)
Rated heating capacity (W)	3000 (PTC)

Rated cooling power (W)	4120 (L35/L35)
Rated heating power (W)	3000 (PTC)
Refrigerant	R134a
Environment temperature (°C)	-30 ~ +55
Relative humidity (%)	5 ~ 100
Transport	Adapted to transportation by train, car, airplane, sea, etc.
IP code	IP55
Material flame retardancy	Meet UL94 requirements
Work lifetime (years)	10
Safety	Meet EN60335, IEC 60950, UL60950, UL1995 and UL484 requirements
Working altitude (m)	≤2000 (Derating at high altitude)
Environmental protection	Meet RoHS 2.0 requirements
Dimensions H×W×D (mm) (with flange size)	1770×620×300

Mass (kg)

125

3.5 Introduction to the MPS series hybrid inverter

3.5.1 Main features

The MPS series hybrid inverter is a microgrid-type photovoltaic, and storage integrated machine designed for areas without electricity or with weak electrical infrastructure, capable of significantly improving the local power supply. This product integrates a photovoltaic controller, an energy storage converter, an isolation transformer, and an STS for grid-tied/off-grid switching. It also features built-in dry contacts for diesel generators, interfaces for load, battery and photovoltaic, significantly increasing system integration and reducing installation costs, bringing an electrical solution to countries and regions around the world facing power supply shortages.

Features:

- (1) Efficiency exceeding 95%.
- (2) Adjustable active and reactive power.
- (3) Built-in isolation transformer.
- (4) Built-in STS and maintenance bypass circuit.
- (5) Equipped with a manual DC input disconnect switch, an AC grid manual disconnect switch, and an emergency shutdown switch.
- (6) Equipped with an advanced islanding detection solution.

(7) Comprehensive protection features, including overload, short-circuit, and grid anomaly protection and alerts.

(8) Product design lifespan exceeds 10 years.

(9) Wide battery input voltage range (450V to 850V) and photovoltaic (PV) input voltage range (250V to 1000V).

(10) A user-friendly touch LCD interface, operated via buttons, clearly displays real-time operational data, real-time fault data, historical fault data (at least 50 entries), total power generation data, and historical power generation data (retrieve by month and year).

(11) Support cluster control mode operation and feature comprehensive monitoring capability.

(12) Provide remote communication interfaces including RS485 or Ethernet. The RS485 interface adheres to the Modbus communication protocol. The Ethernet interface supports TCP/IP and allows for dynamic (DHCP) or static IP address acquisition.

3.5.2 Technical advantages

Advantage	Technical Parameters	Description
Inverter efficiency	Maximum efficiency >95%	The MPS series hybrid inverter adopts an industrial frequency integrated design approach, effectively improving the power quality and system efficiency of the inverter. It adopts a variety of advanced energy-saving concepts, including the latest IGBT technology from Infineon, optimized multistage SVPWM control technology, low-loss magnetic component design, lossless DC bus discharge technology, and display sleep mode technology.
Reactive power regulation function	Power Factor adjusting range: 0.9 lead~0.9 lag Regulation precision: 0.1%	The MPS series energy storage converter is equipped with independent power factor control functionality for outputting power at a specified power factor. The power factor regulation precision is 0.01, with a standard power factor adjustment range of (-1, -0.9] and [+0.9, 1). When operating at full power output, it can still provide an additional 230kVar reactive power.
IGBT module	Infineon's latest generation of low-loss IGBT semiconductor devices	Using Infineon IGBTs as power switching devices and employing a mature and stable two-level inverter technology, along with precise theoretical calculations to determine the optimal IGBT parallel configuration, minimizes the overall losses of the inverter. As a result, the inverter achieves extremely high efficiency.
Cooling fan	EMB high-pressure centrifugal fan	The redundant design of the cooling fans and multi-stage AC fan fault detection technology enable real-time monitoring of each AC fan inside the machine, resulting in immediate warnings when faults occur.
Extended temperature operating capability	Range: -30°C ~ +55°C	The converter has an operating temperature range of -30°C to +55°C. When the temperature exceeds 55°C, the inverter will automatically reduce its output power.

Maximum operating altitude at full load	3000m	The product incorporates redundancy in both electrical and structural design to meet the requirement of continuous full-load operation at an altitude of 3000 meters.
Dual power supply redundancy solution	AC and DC dual power supply	The product adopts an AC and DC dual power redundancy supply design to ensure long-term reliability during operation.
Comprehensive fault protection mechanism	Equipped	The system includes redundant backup for the control power supply, as well as fault monitoring and alarm functions for the control power supply. In-machine 'fault recording' allows for the replay of data at the time of the fault, enabling rapid fault localization.

3.5.3 Key technical parameter

The main parameters of MPS0500 are shown in the following table:

AC (grid-connected)

Maximum output power	550kVA
Rated output power	500kW
Rated voltage	400V
Rated current	722A
Voltage range	320V-460V
Rated frequency	50Hz
Frequency Range	45-55Hz

THDI	<3%
Power Factor	1.0(0.8 leading ~ 0.8lagingg (settable)
AC	3W+N+PE
Isolation transformer	315/400
AC (off grid)	
Maximum output power	550kVA
Rated output power	500kW
Rated voltage	400V
Rated current	722A
THDU	≤1% linear; ≤5% nonlinear
Rated frequency	50Hz
Overload capacity	110% long-term
PV input	
Maximum PV input voltage	1000VDC
Maximum PV power	600kW
MPPT operating voltage range	250~850VDC
MPPT full load voltage range	450~850VDC
Battery	
Battery voltage range	500 ~ 850V
Maximum charging power	550kW

General data

Dimensions (width/depth/height) mm	(600*720*2,050) *2+1,600*1050*2,050
Weight	3,265kg
Operating temperature	-30°C to +55°C
Humidity	0 ~ 95% non-condensing
Degree of protection	IP20
Noise	< 70dB
Altitude	5000m (derating above 3000m)
Cooling method	Air cooling

Communication

Show	Touch LCD display
BMS communication	RS485, CAN
EMS communication	RS485, TCP/IP

3.6 Introduction to energy management systems (EMS)

The EMS system for energy storage system consists of two parts: the EMS data acquisition devices and the Little Sun cloud platform/mobile app. The ES-01 series EMS (with 10.1-inch monitor) serves as the local EMS backend for data acquisition and strategy execution in the system, achieving local data visualization and configuration. Little Sun cloud platform/mobile app serves as the remote EMS backend, achieving remote data visualization and configuration.

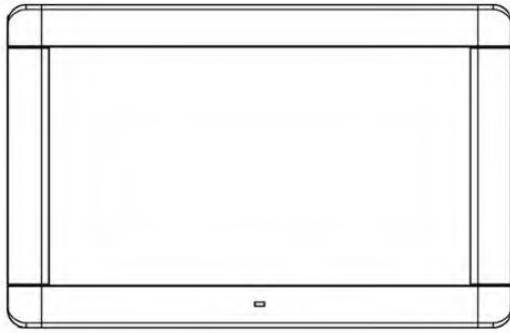

ES-01 front screen

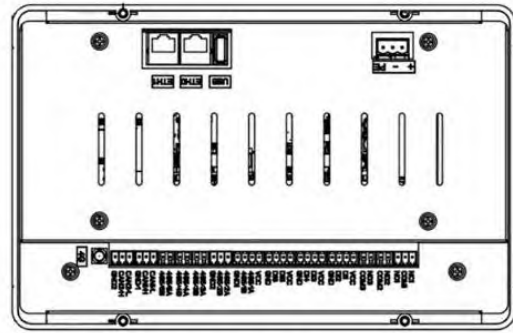

ES-01 Rear Terminal

The functions of the ES series EMS are shown below:

Function		Description
Monitor	SCADA	Device data, including topology maps, status, alerts, etc.
	PCS	PCS analog data, status, real-time data, information and alerts.
	BMS	BMS analog data, status, information and alerts, SOC, SOH, etc.
	Air conditioning	Air conditioning analog data, status, information and alerts.
	Other devices	Fire safety equipment, environmental monitoring equipment, etc.
Alert	Operation alerts	PCS alerts, air conditioning alerts, battery alerts, etc.
	Communication alerts	Communication anomaly alerts.

Function		Description
Scheduling	Various scheduling strategies	Such as peak shaving, steady-state expansion, and transient expansion.
	Log	
statistics	PCS log	Record alerts generated during PCS operation.
	BMS log	Record alerts generated during BMS operation.
	Air conditioning log	Record alerts generated during air conditioning operation.
	Scheduling log	Record local/remote scheduling.
	Charging statistics	Charging curves for today, this month, and this year.
	Discharging statistics	Discharging curves for today, this month, and this year.
	Power generation statistics	Power generation curves for today, this month, and this year.
	Power purchase statistics	Power purchase curves for today, this month, and this year.
Maintenance	Remote upgrade	Remote upgrade PCS, remote upgrade BMS.
	Remote debugging	Remote debugging of field equipment
	Remote parameters setting	Remote adjustment of device parameters

3.6.1 Data acquisition

The ES series EMS device collects and parses the relevant data from device, including field bus interface devices and non-intelligent interface devices (via dry contact signals). For the device connected via Ethernet, the EMS controller and various networked devices can be interconnected through the configured switch. The devices connected via RS485 can be connected to the EMS controller after daisy chaining. The devices connected via dry contact, such as fire safety and smoke detectors, can be connected to the EMS controller via dry contact signals.

3.6.2 Energy management and scheduling

To enhance the robustness and real-time control of the system, the ES series EMS collects data from devices while serving as the executor of the energy storage system's control strategies:

- (1) Built-in control modes for various energy storage systems.
- (2) Coordinated control of equipment with system protection.

3.6.3 Cloud monitoring

If a convenient remote access to the EMS system is required, it can be achieved through the following methods:

The ES-01 series EMS is equipped with a 4G communication module, enabling multi-backend data distribution. It can simultaneously send data to the local 10.1-inch monitor as well as the Little Sun cloud platform/mobile app, which leverages cloud infrastructure to quickly achieve cloud monitoring. Simply insert a local 4G SIM card

into the ES-01 series EMS to upload data to the cloud. The cloud platform monitoring interface is shown as below:

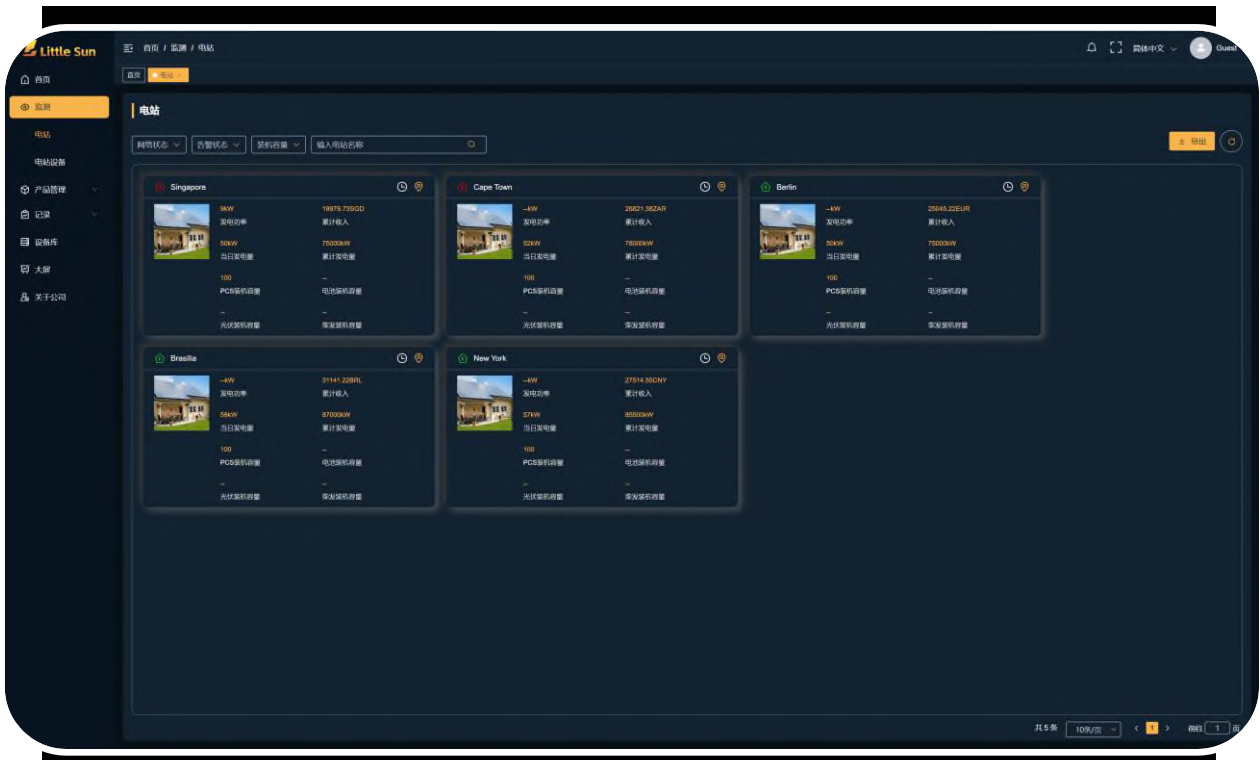
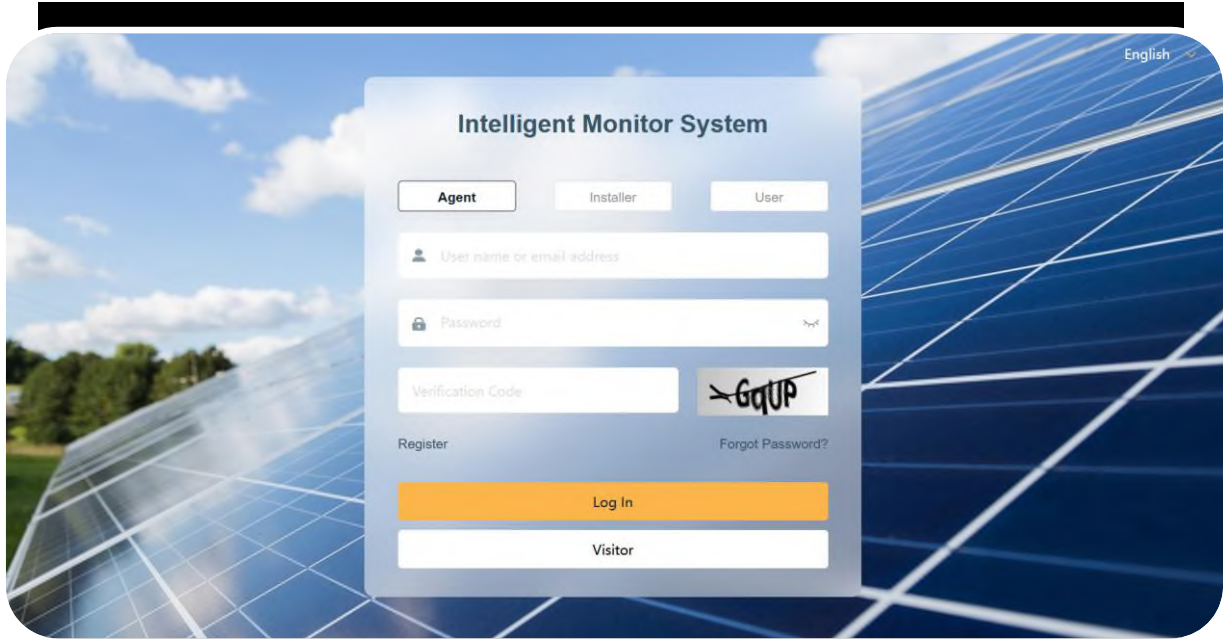

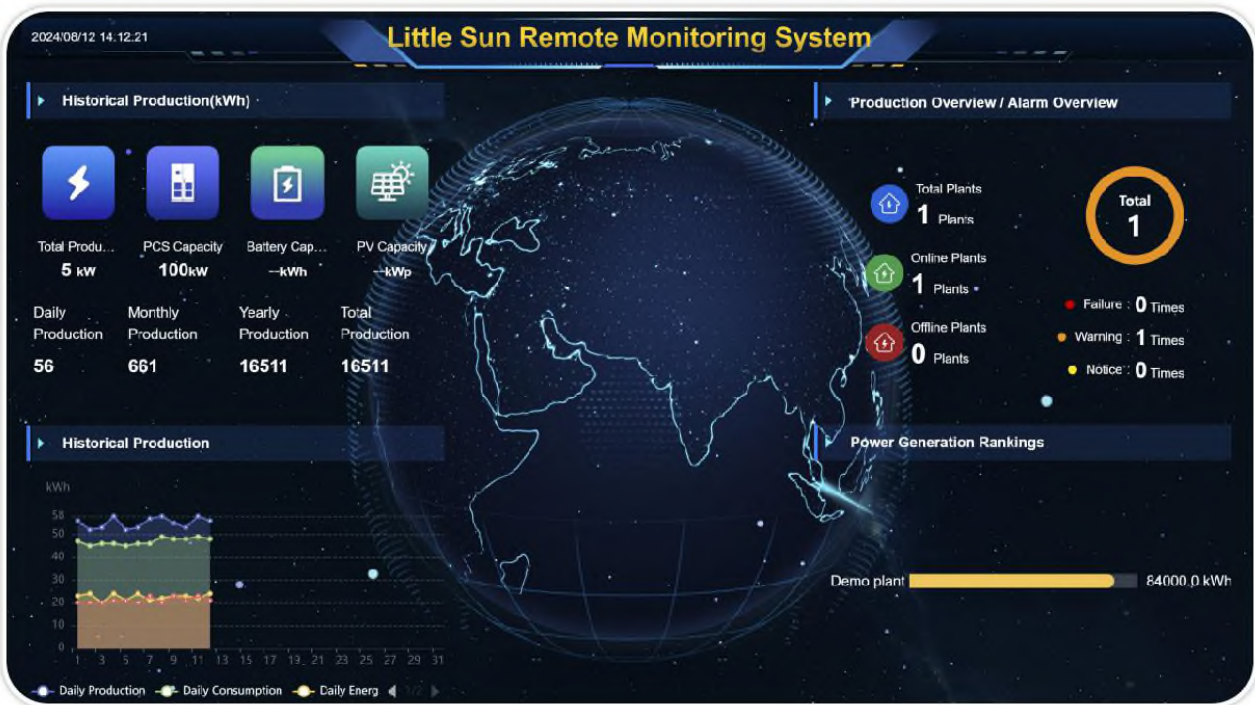
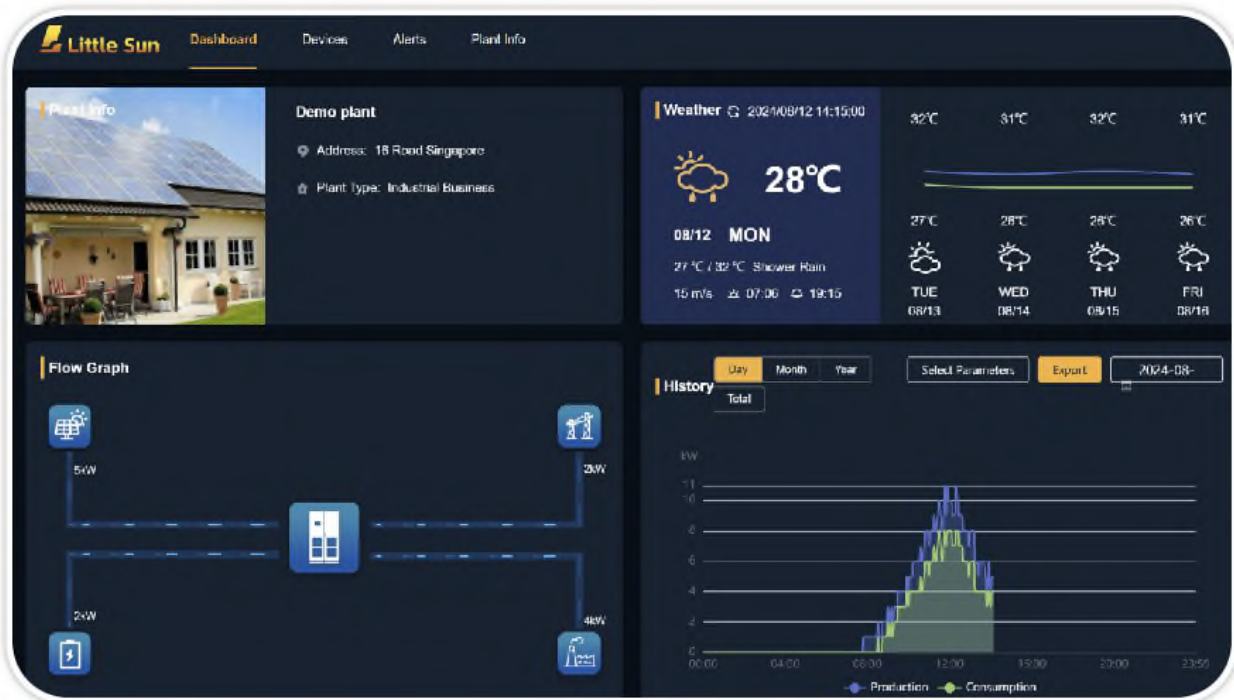

4. Supply List

The scope of supply includes 1 set of 500kW/1MWh 20 feet container energy storage system, which consists of 1.075MWh lithium iron phosphate battery system (including main parts such as the battery packs, BMS, power distribution combiner boxes and other auxiliary components), MPS0500 and EMS. The supply list of this project is shown in the following table:

Serial number	Equipment name	Type and specification	Unit	Quantity	Remarks
1	Container energy storage system	500kW/1.075MWh	Set	1	Each container system includes 1.1~1.8.
1.1	Hybrid inverter	MPS0500	Set	1	Each MPS0500 has 10 MPPT modules configured. Built-in isolation transformer and STS for on/off-grid switching.
1.2	Lithium iron phosphate battery system	1.075MWh	Set	1	Cell: 3.2V/280Ah. Pack: 51.2V/280Ah (1P16S). Battery Cluster: 768V/280Ah (1P240S) A total of 5 groups of battery clusters.

Including battery rack, BMS, combiner boxes, etc.					
1.2.1	BMS	-	Set	1	-
1.2.2	Battery cabinets	215.04kWh	Set	5	-
1.2.3	Power distribution combiner cabinet	-	Set	1	-
1.3	UPS	2kVA	Set	1	-
1.4	Cables	-	Set	1	Battery cluster to MPS input side, including power cables, auxiliary power cables, and communication cables
1.5	Container and auxiliary components	-	Set	1	20 feet container
1.6	EMS	ES-01	Set	1	Remote Monitoring included. Intelligent gateway included.

1.7	Fire protection system	FM200 (or NOVEC1230)	Set	1	-
1.8	Air conditioning	9kW	Set	2	-
